

# Aprilaire®

## ELECTRONIC THERMOSTATS



### MODEL 8336

#### 2 Heat / 2 Cool Digital Heat Pump

#### User's Manual Installation and Operation



## IMPORTANT SAFETY INFORMATION

### WARNING:

- Always turn off power at the main power source by unscrewing fuse or switching circuit breaker to the off position before installing, removing, cleaning, or servicing thermostat.
- Read all of the information in this manual before installing or programming this thermostat.
- This is a 24V AC low-voltage thermostat. Do not install on voltages higher than 30V AC.
- All wiring must conform to local and national building and electrical codes and ordinances.
- Do not short (jumper) across terminals on the gas valve or at the system control to test installation. This will damage the thermostat and void the warranty.

## Features

- Multi Stage heating and cooling control.
- Zone system compatible as a master thermostat.
- Multi-Colored LED indicators for system status.
- Low battery indicator.
- Fahrenheit/Celsius display option.
- Adjustable from 45°F (4°C) to 90°F (32°C).
- Accuracy within  $\pm 1$  degree.
- Adjustable temperature differential: 1-3 degrees F.
- Automatic heating shutdown if temperature exceeds 90°F (32°C).

## Replacing Existing Thermostat

1. Turn off power to heating and cooling system.
2. Remove cover of old thermostat to expose wires.  
Do not disconnect wires. (Fig. 1)
3. Label wires per Table 1.

**Table 1**

Old Label	New Label	Description
R, V-VR or VR-R	R	24 VAC, Return
Y, Y1 or M	Y	Stage 1 Cooling/Heating Circuit
O or R	O	Reversing Valve, (Cooling Mode)
B	B	Reversing Valve (Heating Mode)
F or G	G	Fan control relay
Y2	Y2	2nd Stage Cooling Circuit
W1 or W2 or W-U	W2	2nd Stage Heating Control
L or X	L	System Monitor LED
E	E	Emergency Heating Circuit
C, X or B	C	24 VAC, Transformer Common Side

**\*NOTE:** This thermostat requires a 24V common wire for proper operation.

4. After labeling wires, remove wires from terminals.
5. Remove existing thermostat base from wall.
6. Refer to the following section for instructions on how to install thermostat.

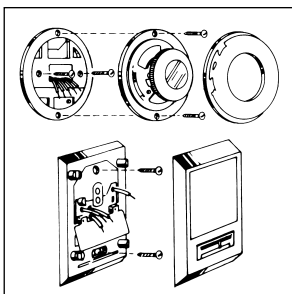
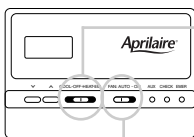

Figure 1

## Installing the Model 8336 Thermostat

**NOTE:** For new installations, mount thermostat on inside wall, 4-5 feet above the floor. Do not install behind a door, in a corner, near air vents, in direct sunlight, or near any heat or steam generating fixtures. Installation at these places will affect thermostat operation.

1. Turn power off to the heating and cooling systems.
2. Place COOL-OFF-HEAT-EM In OFF position.



3. Place FAN: AUTO-ON switch Into AUTO position.
4. Remove the cover using a coin or screwdriver.

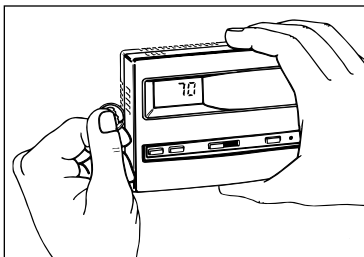

Figure 2

5. Place thermostat against the wall at desired location. Make sure wires will feed through opening on base of thermostat.
6. Mark placement of mounting holes. See Fig. 3.  
Set base aside.

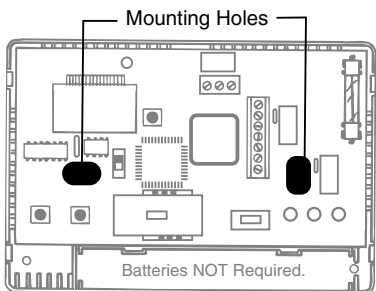
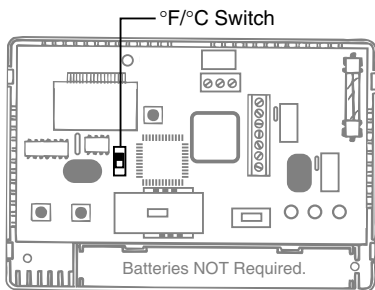

figure 3

7. Drill the marked holes using a 3/16" drill bit. **NOTE: Enclosed plastic anchors do not require a drilled hole for drywall.**
8. Tap plastic anchors into the wall.
9. Align base with plastic anchors and feed wires through opening.
10. Secure base to wall with supplied screws.

11. Connect wires to terminal strip. Refer to wiring diagrams on other side of this sheet. Make sure wire connections are secure.
12. Put the °F/°C switch to either °F for Fahrenheit display or °C for Celsius display readout.



**figure 4**

13. Replace cover onto thermostat by snapping into place.
14. Turn on power to system. Test thermostat as described in the following section.

# Operation

## Setting or Changing the Setpoint Temperature

1. Press either the **▼** or **▲** button.  
The display will show the current temperature setpoint.

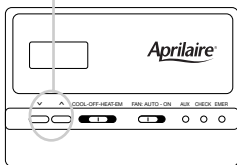

2. Press either the **▼** or **▲** button  
to adjust the temperature setting  
either up or down.

The display will return to the room temperature display five seconds after the last input and the new setpoint will be saved.

## Changing Temperature Differential

**IMPORTANT:** The temperature differential is factory set at 1 (1°). This means that whenever the room temperature changes by one half of a degree from the temperature setting, the system will turn on. If the system turns on too often, increase the temperature differential.

1. Press both **▼** and **▲** buttons  
at the same time and hold for one  
second.

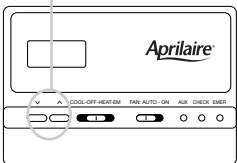

2. Press either the **▼** or **▲** button  
to adjust the temperature  
differential up or down.

The display will show:

Differential Setting	Degrees
1	1°F/.5°C
2	2°F/1.0°C
3	3°F/1.5°C

The display will return to the room temperature five seconds after the last input.

## To Test Thermostat

**WARNING:** DO NOT SHORT (JUMPER) ACROSS TERMINALS OF GAS VALVE OR SYSTEM CONTROL TO TEST OPERATION. THIS WILL DAMAGE THE THERMOSTAT AND VOID YOUR WARRANTY.

**CAUTION:** Do not switch system to cool if the temperature is below 50°F (10°C). This can damage the air conditioning system and cause personal injury.

1. Place the COOL-OFF-HEAT-EM switch into the COOL position
2. Press the **▼** button until the temperature setting is at least 3 degrees below the room temperature. The air conditioning system should turn on within a few seconds.

COOL-OFF-HEAT-EM



**NOTE:** When in the COOL mode (or HEAT for single stage heat pumps), once the thermostat turns off, a built in 5-minute delay prevents the system from turning on again. This protects the compressor. No additional time delay relay is required.

3. Put the COOL-OFF-HEAT-EM switch into the OFF position. The air conditioning system should turn off.
4. Put the COOL-OFF-HEAT-EM switch into the HEAT position.
5. Press the **▲** button until the temperature setting is at least 3 degrees above room temperature. The heating system should turn on. The fan may not turn on immediately, depending upon the fan delay built into the furnace.

COOL-OFF-HEAT-EM



6. Put the COOL-OFF-HEAT-EM switch into the OFF position. The heating system should turn off. The fan may continue to run for a short period of time.

COOL-OFF-HEAT-EM



7. Put the FAN: AUTO-ON switch to the ON position. The blower fan should turn on.
8. Put the FAN: AUTO-ON switch to the AUTO position. The blower fan should turn off.

COOL-OFF-HEAT-EM



FAN: AUTO - ON



FAN: AUTO - ON



## Changing Fahrenheit (F) to Celsius (C)

The thermostat is preset to display the temperature in degrees Fahrenheit. You may change the display readout to Celsius if desired.

1. Move the manual switch marked "F" (Fahrenheit) and "C" (Celsius) located at the top center of the circuit board to the desired setting. (see page 5)
2. Press RESET button located just below the LCD display to register the change.

The display will change to show the temperature in your desired temperature scale. To return the thermostat to its original setting, repeat steps 1 and 2 above.

## LED Indicators

The LED indicators are used to indicate system activity. The AUX indicator illuminates during a call for second stage heating. The auxiliary stages are used to maintain comfort during extremes in weather conditions. If the AUX LED is illuminated too frequently during periods of moderate temperature, check the differential settings (page 6).

The CHECK indicator is used to monitor system status. If the CHECK indicator is illuminated, call your local HVAC service provider.

The EMER indicator is illuminated only when the system switch is moved to the EM, emergency heat position. The EM position is used only when the primary stage of heat is not functioning or requires service.

## Troubleshooting

Symptom	Remedy
Thermostat does not turn on system.	Check Wiring (see INSTALLATION). Check fuse. Replace with 2 amp fuse if fuse has opened.
Thermostat turns on and off too frequently.	Increase Temperature Differential (see DIFFERENTIAL).
System fan does not operate properly.	Move fan option switch to either gas or electric, to match system (see INSTALLATION).
Thermostat does not display proper room temperature.	Check "F" Fahrenheit/"C" Celsius switch located at top center of circuit board for proper position. If a new selection is made, press "RESET" button located directly below LCD display.

**If problems with thermostat cannot be solved, call:**

Technical Support: 608-257-8801  
Monday-Friday 7:45 am-5:00 pm CST

# Wiring Diagrams

The following is just a sample of the most common types of HVAC systems. Refer to your systems installation manual for wiring information.

## APRILAIRE MODEL 8336 HEAT PUMP THERMOSTAT CONVERSION TO CARRIER SPLIT SYSTEM CONDENSORS AND HEAT PUMP SYSTEMS

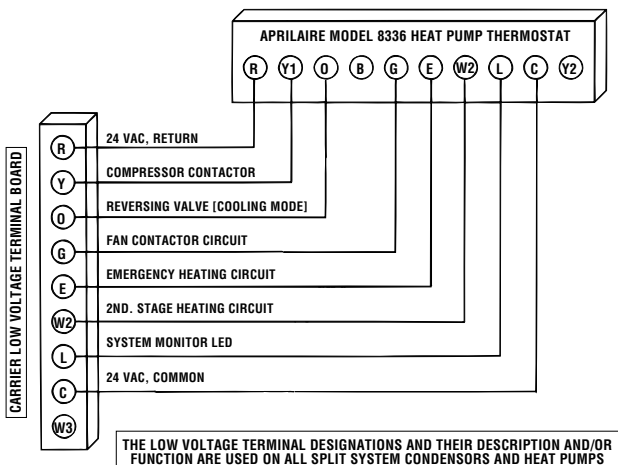

## APRILAIRE MODEL 8336 HEAT PUMP CONVERSION TO COLEMAN HEAT PUMPS 3000 SERIES HEAT PUMP SYSTEMS

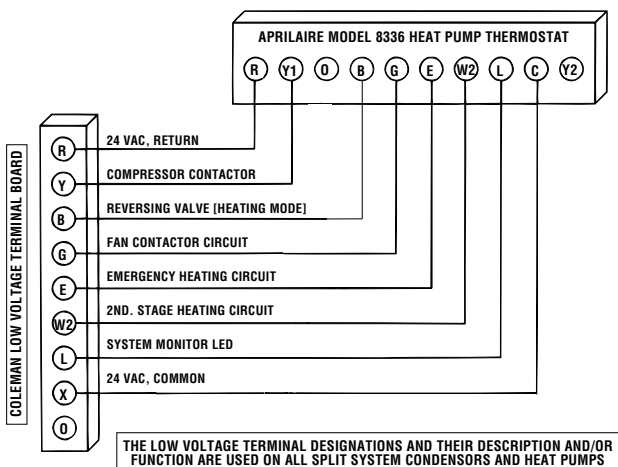

**APRILAIRE MODEL 8336 HEAT PUMP THERMOSTAT CONVERSION TO COMFORTMAKER  
CYC SERIES HEAT PUMP SYSTEMS**

- NOTE 1:** E AND W2 TERMINALS  
JUMPERED AT THERMOSTAT
- NOTE 2:** W2 TERMINAL ON  
COMFORTMAKER PCB CAPPED
- NOTE 3:** X TERMINAL ON  
COMFORTMAKER PCB CAPPED

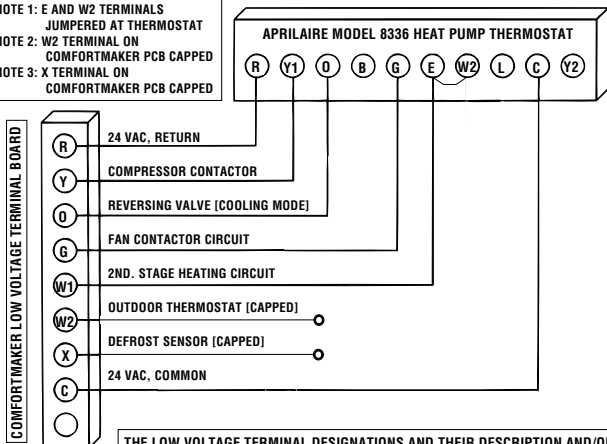

THE LOW VOLTAGE TERMINAL DESIGNATIONS AND THEIR DESCRIPTION AND/OR FUNCTION ARE USED ON ALL SPLIT SYSTEM CONDENSORS AND HEAT PUMPS

**APRILAIRE MODEL 8336 HEAT PUMP THERMOSTAT CONVERSION TO HEIL-QUAKER  
867.814 SERIES AND PH50 SERIES HEAT PUMP SYSTEMS**

- NOTE 1:** E AND W2 TERMINALS  
JUMPERED AT THERMOSTAT
- NOTE 2:** W2 TERMINAL ON  
HEIL-QUAKER PCB CAPPED

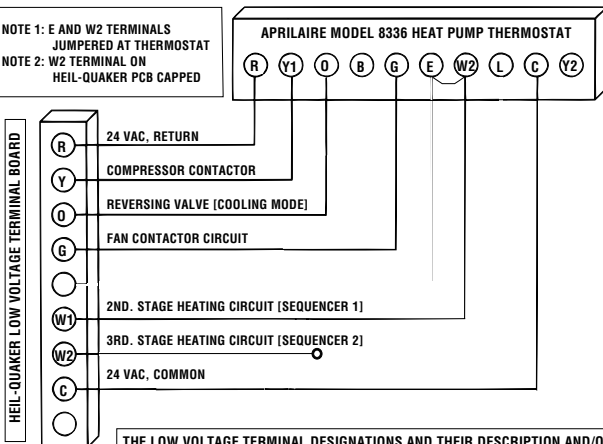

THE LOW VOLTAGE TERMINAL DESIGNATIONS AND THEIR DESCRIPTION AND/OR FUNCTION ARE USED ON ALL SPLIT SYSTEM CONDENSORS AND HEAT PUMPS

**APRILAIRE MODEL 8336 HEAT PUMP THERMOSTAT CONVERSION TO PAYNE  
RELIANT AND ENDURA MODEL HEAT PUMP SYSTEMS**

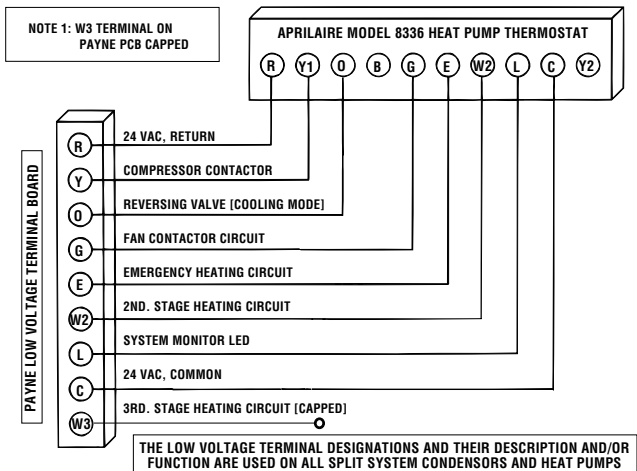

**APRILAIRE MODEL 8336 HEAT PUMP THERMOSTAT CONVERSION TO RHEEM/RUUD  
HEAT PUMP SYSTEMS**

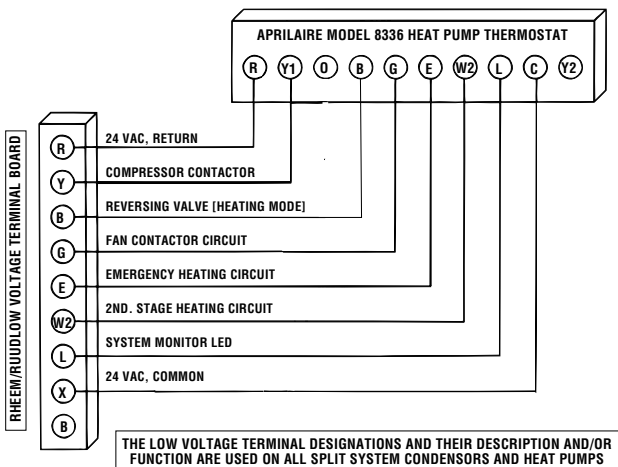

**APRILAIRE MODEL 8336 HEAT PUMP THERMOSTAT CONVERSION  
TO WEATHERTRON HEAT PUMPS**

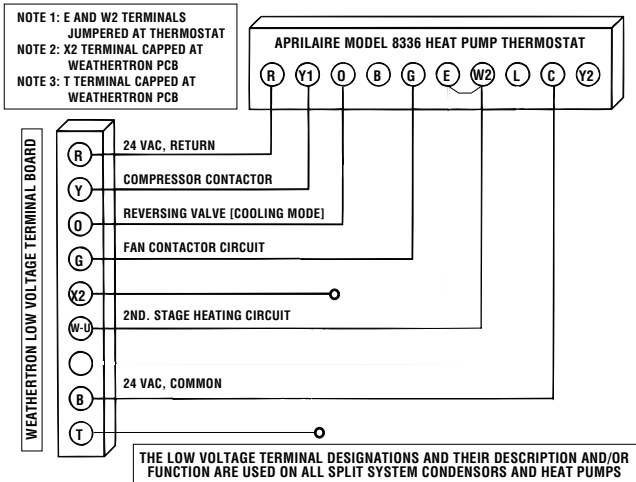

**APRILAIRE MODEL 8336 HEAT PUMP THERMOSTAT CONVERSION TO YORK  
-E1CS, -E1FB, -E1FH HEAT PUMP SYSTEMS**

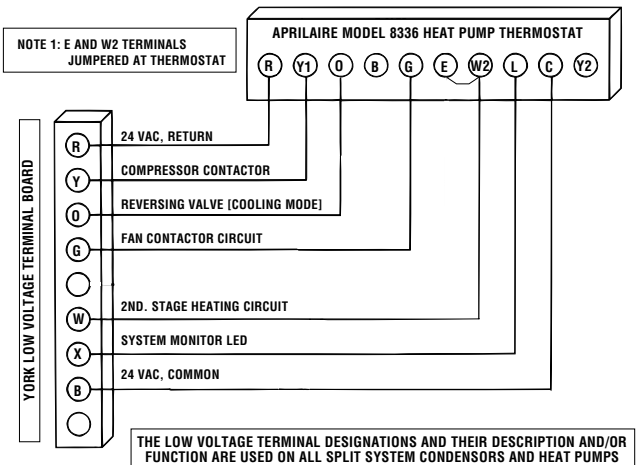

**APRILAIRE MODEL 8336 HEAT PUMP THERMOSTAT CONVERSION TO LENNOX CB19 HEAT PUMP SYSTEMS**

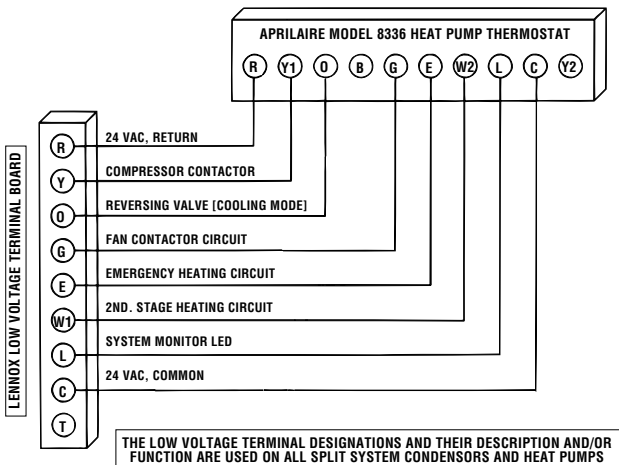

**APRILAIRE MODEL 8336 HEAT PUMP THERMOSTAT CONVERSION TO LENNOX HP19 AND HP20 HEAT PUMP SYSTEMS**

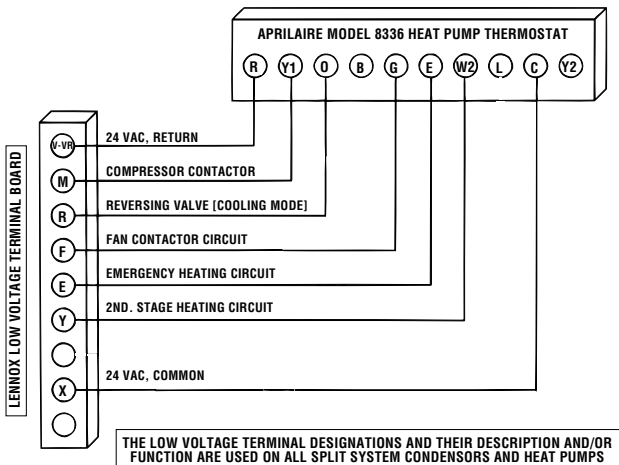

**APRILAIRE MODEL 8336 HEAT PUMP THERMOSTAT CONVERSION TO LENNOX HP21 WITH CB21 PCB HEAT PUMP SYSTEMS**

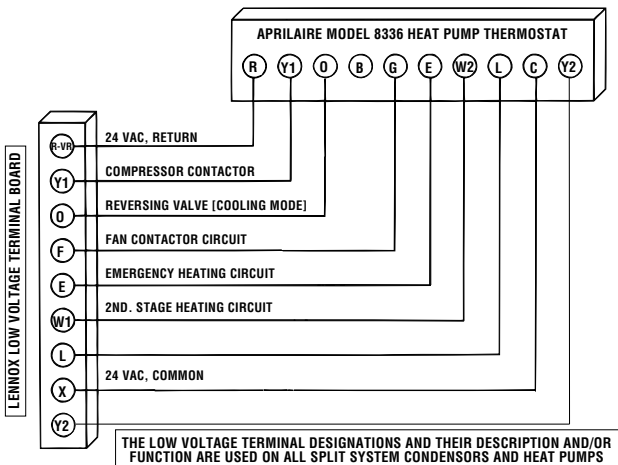

**APRILAIRE MODEL 8336 HEAT PUMP THERMOSTAT CONVERSION TO LENNOX HP22 WITH CB19 PCB HEAT PUMP SYSTEMS**

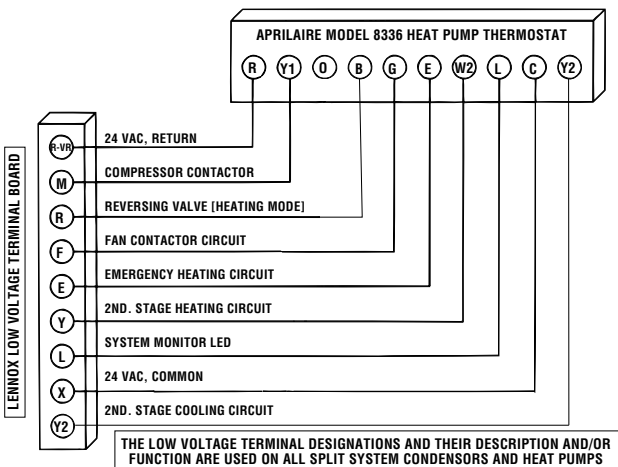

# Limited Warranty

Your Research Products Corporation Aprilaire® Thermostat unit is expressly warranted for two (2) years from date of installation to be free from defects in materials and workmanship.

Research Products Corporation's exclusive obligation under this warranty shall be to supply, without charge, a replacement for any thermostat which is found to be defective within a two (2) year period and which is returned, together with the date of installation, no later than thirty (30) days after said two (2) year period by you to either your original supplier or to Research Products Corporation, Madison, Wisconsin 53701.

THIS WARRANTY SHALL NOT OBLIGATE RESEARCH PRODUCTS CORPORATION FOR ANY LABOR COSTS AND SHALL NOT APPLY TO DEFECTS IN WORKMANSHIP OR MATERIALS FURNISHED BY YOUR INSTALLER AS CONTRASTED TO DEFECTS IN THE THERMOSTAT ITSELF.

IMPLIED WARRANTIES OF MERCHANTABILITY OR FITNESS FOR A PARTICULAR PURPOSE SHALL BE LIMITED IN DURATION TO THE AFORESAID TWO YEAR PERIOD. RESEARCH PRODUCTS CORPORATION'S LIABILITY FOR INCIDENTAL OR CONSEQUENTIAL DAMAGES, OTHER THAN DAMAGES FOR PERSONAL INJURIES, RESULTING FROM ANY BREACH OF THE AFORESAID IMPLIED WARRANTIES OR THE ABOVE LIMITED WARRANTY IS EXPRESSLY EXCLUDED. THIS LIMITED WARRANTY IS VOID IF DEFECT(S) RESULT FROM FAILURE TO HAVE THIS THERMOSTAT INSTALLED BY A QUALIFIED HEATING AND AIR CONDITIONING CONTRACTOR. IF THE LIMITED WARRANTY IS VOID DUE TO FAILURE TO USE A QUALIFIED CONTRACTOR, ALL DISCLAIMERS OF IMPLIED WARRANTIES SHALL BE EFFECTIVE UPON INSTALLATION.

Some states do not allow limitations on how long an implied warranty lasts or the exclusion or limitation of incidental or consequential damages, so the above exclusion or limitations may not apply to you.

This warranty gives you specific legal rights and you may also have other rights which vary from state to state.



P.O. BOX 1467 • MADISON, WI 53701-1467

*Products For Better Indoor Air Quality™*